



APMA

S8520A

**Single-channel
Optical Transmitter Module**

User's Manual



Contents

1. Product Description.....	1
2. Product Features.....	1
3. Product Ordering Information.....	1
4. Product Performance Indicators.....	2
4.1 Absolute Maximum Ratings.....	2
4.2 Recommended Working Conditions.....	2
4.3 Product Optoelectronic Properties.....	3
5. Interface Definition.....	3
5.1 Electrical Interface Definition.....	3
5.2 Optical Interface Definition.....	4
6. Dimensions.....	5
7. Application Design Guidance.....	5
7.1 Peripheral Configuration Recommended Circuit.....	5
7.2 Power Adaptability.....	6
8. Recommended PCB LAYOUT design	6
9. Precautions For Use.....	7
9.1 Eye Safety Protection.....	7
9.2 Preparation Before Installation and Soldering.....	7
9.3 Module Soldering.....	7
9.4 Module Disassembly.....	8
9.5 Three Prevention Treatment.....	8
9.6 Module Storage Requirements.....	9
9.7 Module Protection.....	9



1. Product Description

S8520A optical module is a low-power, high-performance single-channel optical transmitter module. The operating wavelength of the module is 850nm, the transmission rate supports 50Mbps ~ 3.19Gbps, the operating temperature range is -55°C ~ 85°C, the optical interface adopts a customized 8# optical pin interface, the electrical interface is a 6-pin solder pin, and the module package size is $\Phi 8\text{mm} \times 23\text{mm}$.

A schematic diagram of the product appearance is shown in Figure 1.

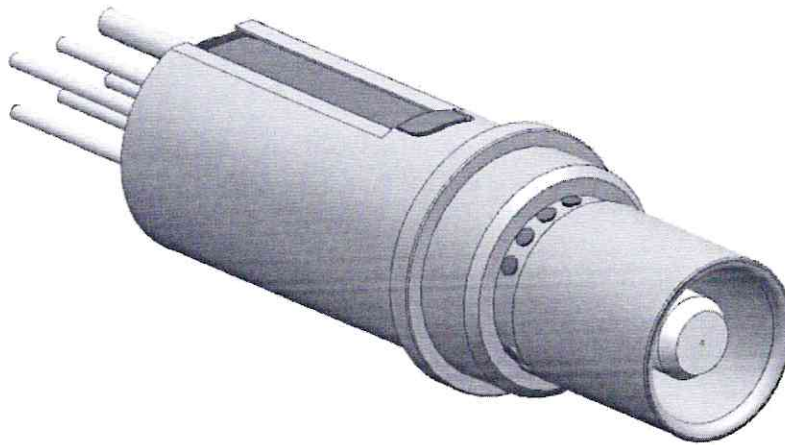

*Only a schematic diagram of the appearance, the actual product shall prevail.

Figure 1 Schematic diagram of the appearance

2. Product Features

- +3.30V DC power supply
- 8# optical pin interface, 50/125 μm optical interface
- 50Mbps ~ 3.19Gbps transmission rate
- 850nm VCSEL laser, multi-mode fiber, transmission distance 300m@3.19Gbps, OM3
- Overall dimensions: $\Phi 8\text{mm} \times 23\text{mm}$
- Working temperature range: -55°C ~ 85°C

3. Product Ordering Information

Partnumber for Order: **S8520A**



4. Product Performance Indicators

4.1 Absolute Maximum Ratings

Table 1 Absolute Maximum Ratings

Parameter	Symbol	Unit	Numerical value		Remark
			Min. value	Max. value	
Supply voltage	V _{CC}	V	0	3.60	-
Control signal input voltage	V _{ctr-in}	V	0	V _{CC}	-
Storage temperature	T _{stg}	°C	-55	100	-
Relative operating humidity	RH ₀	%	5	85	-
ESD protection value	ESD	V	-	2200	-
Soldering temperature	T _{sold}	°C	-	260	-
Soldering time	t _{sold}	s	1	3	-
Soldering number of times	N _{sold}	number	1	2	-

Note: Use beyond the above extreme conditions may cause irreparable damage to the product. Working under extreme working conditions is not recommended.

4.2 Recommended Working Conditions

Table 2 Recommended Working Conditions

Description	Symbol	Numerical value			Unit	Remark
		Min. value	Typical value	Max. value		
Operating voltage	V _{CC}	3.135	3.30	3.465	V	-
Operating temperature	T _{amb}	-55	25	85	°C	-
Power ripple	VSND	-	-	+200	mV	peak-to-peak
Differential input matching impedance	Z _{in}	-	100	-	Ω	-
Differential signal input voltage	V _{diff-in}	250	-	2200	mV	peak-to-peak
Transmitter enable control high state	Tx-dish	2	-	V _{CC}	V	-
Transmitter enable control low state	Tx-disl	0	-	0.8	V	-
Transmission rate	S	0.05	3.19	3.19	Gbps	-
Transmission distance	D	-	-	300	m	OM3

4.3 Product Optoelectronic Properties

Table 3 Optoelectronic Performance Indicators

Description	Symbol	Numerical value			Unit	Remark
		Min. value	Typical value	Max. value		
Working current	I_{cc}	-	-	110	mA	-
Power consumption	P	-	-	0.381	W	-
Emission photoelectric characteristics (-55°C ~ 85°C, 3.19Gbps, PRBS 2 ⁷ -1, V _{CC} = 3.30V)						
Description	Symbol	Numerical value			Unit	Remark
		Min. value	Typical value	Max. value		
Average emitted optical power	P_o	-6.5	-	-1.0	dBm	-
Central wavelength	λ	830	850	860	nm	-
RMS spectrum width	$\Delta\lambda$	-	-	0.85	nm	-
Extinction ratio	ER	6	-	-	dB	-

5. Interface Definition

5.1 Electrical Interface Definition

Facing the electrical interface, the pin definition of the electrical interface is shown in Figure 2.

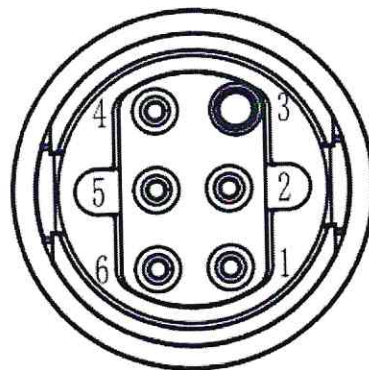

Figure 2 Electrical pin definition diagram



Table 4 Electrical pin definition description

Serial number	Name	Level type	I/O	Pin definition	Remark
1	TX_DIS	CMOS	I	Transmitter enable control	Low level: The transmitter is on; High level: The transmitter is turned off. The module has an internal pull-down resistor of about 4.7k Ω .
2	VCC	-	-	Power supply	3.30V
3	GND	-	-	Ground	-
4	TX_Fault	CMOS open-drain output	O	Send error alert	Low level: normal operation; High level: transmission error. The motherboard needs to pull up a 4.7k Ω ~ 10k Ω resistor.
5	TX-	CML	I	Transmitter inverting input	Differential 100 Ω , AC coupling, requires external 0.1 μ F coupling capacitor.
6	TX+	CML	I	Transmitter positive input	Differential 100 Ω , AC coupling, requires external 0.1 μ F coupling capacitor.

5.2 Optical Interface Definition

Facing the optical interface, the optical interface is shown in Figure 3. The typical diameter of the ceramic ferrule is 2.5mm.

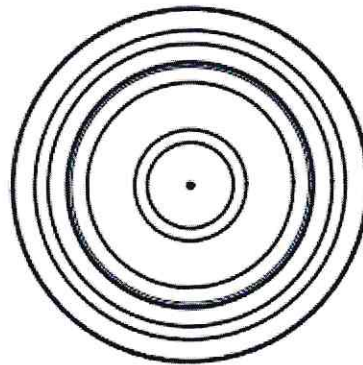

Figure 3 Optical interface definition diagram



6. Dimensions

The overall dimensions of the module are shown in Figure 4, unit: mm, tolerance $\pm 0.2\text{mm}$ is not noted.

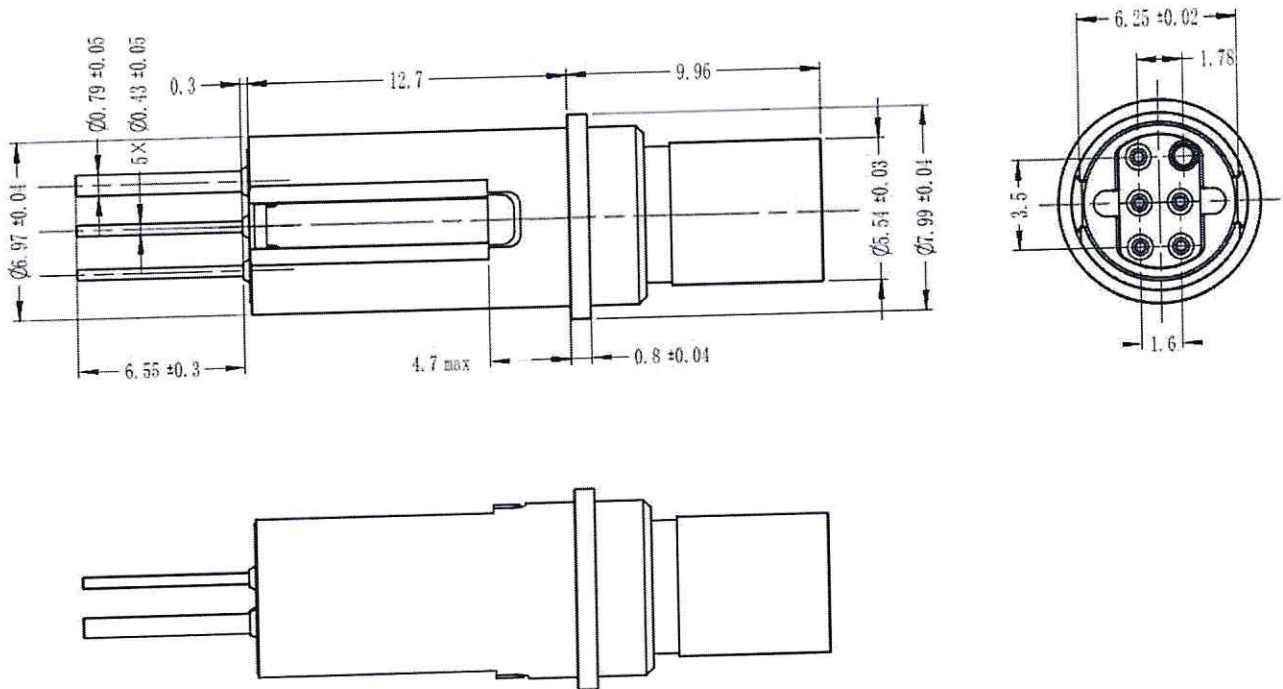

Figure 4 Module dimensions drawing

7. Application Design Guidance

7.1 Peripheral Configuration Recommended Circuit

The reference peripheral filter circuit is shown in Figure 5.

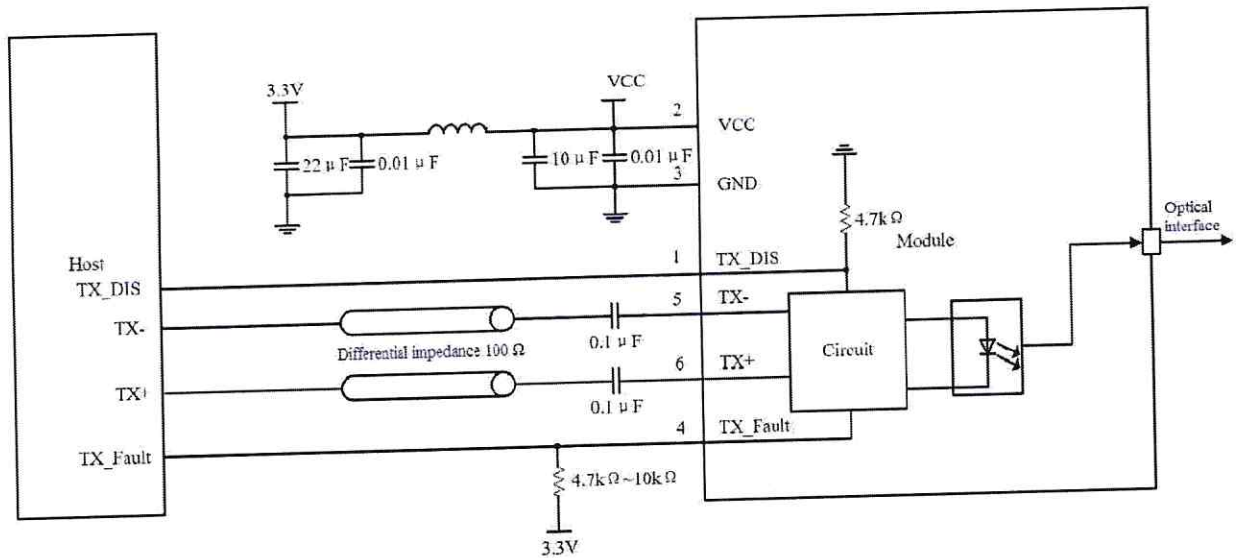

Figure 5 Recommended peripheral configuration

Design considerations:

- The inductor in the power supply filter circuit must have sufficient overcurrent capability;
- High-speed signal routing ensures a differential of 100Ω;
- The high-speed signal between HOST and module adopts AC coupling design, and it is recommended to design a 0.1µF coupling capacitor;
- In the high-speed signal path, the via hole is the key point that affects the impedance, so pay attention to it during layout;
- The module metal shell is connected to the signal ground. It is recommended that users add electrical isolation measures according to system insulation requirements during installation and use, while ensuring effective electromagnetic compatibility and electrostatic protection measures. It is recommended to connect the module metal shell to the system signal ground.
- The recommended circuit is for reference only.

7.2 Power Adaptability

In order to ensure the stable and reliable operation of the module, users should pay attention to the following matters when using it:

- The load capacity of the power supply module on the motherboard must be sufficient. Each optical module needs to place a filter circuit as close as possible to the module power pin to filter the power supply. Please refer to Figure 5 for power supply part design and filtering. The inductor in the circuit must have sufficient overcurrent capability, and the inductance value can be adjusted appropriately;
- The module can only be used within the limit supply voltage range. If the limit voltage is exceeded, the module may be irreversibly damaged. Only within the recommended index range can the module work stably and reliably for a long time.

8. Recommended PCB LAYOUT design

- The PCB Layout design and packaging diagram of this optical module product corresponding to the user's motherboard is shown in Figure 6.

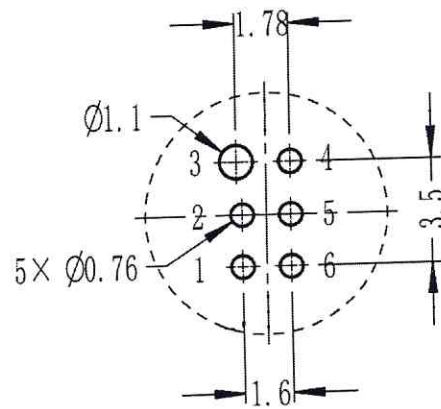

Figure 6 Recommended motherboard PCB layout design dimensions (top view)

b) Optical module Pin delay information:

The high-speed differential lines inside the optical module have been designed with equal lengths. The length of the high-speed differential pair signal lines on the user's motherboard is controlled within 5 mil.

c) PCB board material requirements: It is recommended to choose Middle Low Loss level material ($0.012 \leq Df < 0.016$).

9. Precautions For Use

9.1 Eye Safety Protection

It is forbidden to look directly at the laser outlet with eyes to prevent laser damage to human eyes; it is generally safe to observe diffuse reflection, but when observing the laser with optical instruments such as a microscope or telescope, the laser beam can cause damage to the eyes.

9.2 Preparation Before Installation and Soldering

- Module picking: When picking up a pluggable single-channel optical module from the packaging box, if there is a small pad at the rear end of the optical module, use tweezers to remove the small pad first, and then pick up the main body of the optical module. Pay attention to electrostatic protection when picking up and do not damage the pin header.
- It is recommended to clean the pads and pin headers before soldering (clean them with ethanol and wait until the ethanol has completely evaporated before soldering).
- When manual soldering is used, operators are required to wear anti-static wrist straps, anti-static finger cots or gloves; heating table soldering, wave soldering and reflow soldering are prohibited.
- It is recommended to use 63Sn/37Pb solder for soldering.
- When cleaning and soldering, the optical interface requires wearing a dust cap/plug.

9.3 Module Soldering

- During the soldering process, anti-static protection measures must be taken, and an anti-static soldering iron (ground resistance less than 10 ohms) must be used; operators are required to wear anti-static wrist straps, and the environmental anti-static level meets the Class 1 requirements of the S20.20 standard; It is recommended to use a pointed soldering iron to ensure good heat transfer at the temperature of the soldering iron tip. It is required that the soldering temperature should be kept within 260°C during soldering (the soldering iron tip is in contact with the PCB pad).
- Aerospace products can be tinned on the motherboard PCBA pad. Note: The solder in the tinned area should be as thin as possible, and the solder height must be the same. Undesirable phenomena such as tin wrapping and continuous soldering are not allowed, otherwise the pins will be damaged, it can easily lead to poor soldering.



- c) When soldering, it is required to press the module so that the module pins are in full contact with the pads on the motherboard to avoid false soldering.
 - d) The recommended soldering method is single-point soldering. The soldering time for each time the soldering iron touches the pad should be less than 3 seconds. When a single point is not soldered, it needs to stay for 3 seconds before soldering the solder point (if the customer uses drag soldering, be sure to ensure anti-static , avoid continuous soldering).
 - e) The entire module must be re-soldered no more than 2 times (i.e. one opportunity for repair is allowed).
 - f) When soldering, it is prohibited to touch the soldering iron tip to the outer shell.
 - g) After soldering, clean. It is recommended to use a small anti-static brush, absorbent cotton and cleaning agent to clean the soldering joint and remove rosin, tin beads and other excess materials.
- Note 1: It is prohibited to immerse the module in cleaning fluid for cleaning or use ultrasonic waves for cleaning;
Note 2: The optical port needs to be protected during the cleaning process to prevent optical port contamination.
- h) Post-solder inspection
 - 1) The soldering quality requirements refer to IPC-A-610 D.
 - 2) After soldering, before powering on, check whether the power pin and the ground pin are short-circuited.

9.4 Module Disassembly

9.4.1 Preparation before disassembly

Manual disassembly is required, and operators are required to wear anti-static wrist straps, anti-static finger cots or gloves;

9.4.2 Disassembly operation requirements

- a) During the disassembly process, take anti-static protection measures, use an anti-static soldering iron tip (the ground resistance is less than 10 ohms), and the environmental anti-static level requirement is less than 100V.
- b) When disassembling, ensure that the temperature of the soldering iron tip is good and the solder of the module pin header can be melted at the same time.
- c) Disassemble it after the actual temperature of the soldering iron reaches the required temperature. It is recommended that the temperature of the soldering iron tip be controlled between $310^{\circ}\text{C}\pm 10^{\circ}\text{C}$ and the contact time be less than 10s during disassembly. When disassembling, if the amount of solder is small, an appropriate amount of solder must be applied to the contact surface between the soldering iron tip and the module pin header to ensure that the soldering iron tip is in full contact with the solder joints of each pin row. At the same time, the solder must not overflow and stick to the module.
- d) After each solder joint is melted, carefully grasp the module with your hands and remove the module.
- e) After disassembly, clean the solder on the module pin headers to ensure that there is no short circuit between the pin headers and that the pin headers are flat.

9.5 Three Prevention Treatment

- a) Use ethanol to clean the module surface and wait until the ethanol has completely evaporated before proceeding with subsequent operations.
- b) Before applying conformal anti-paint, protect the optical port and electrical port. The optical port needs to wear a dust cap/plug; protect the electrical port as follows: use solder mask to protect the electrical port pin header to prevent spraying, problems such as poor soldering after applying conformal paint.
- c) Use the brushing process to coat the surface of the module with conformal protective paint. It is prohibited to use the dip coating process to prevent the conformal protective paint from contaminating the interior of the module, causing the module to work abnormally and become unusable.
Note: It is recommended to use self-drying. If drying is required, the drying temperature should not be higher than the maximum storage temperature of the module.
- d) After the three-proof paint on the module surface is completely dry, remove the solder mask on the electrical port pad;
 - 1) It is prohibited to use metal tools to remove the solder mask from the electrical port pad;
 - 2) If the module is soldered behind the user's system board and coated with conformal anti-corrosion paint, there is no need to protect the electrical port. Only the module surface and the soldering joint need to be cleaned. The coating requirements are the same as those for single products;
 - 3) It is recommended to use non-volatile conformal paint. Volatile conformal paint can easily contaminate the optical port.



9.6 Module Storage Requirements

- a) The module should be stored in a dry, ventilated, and non-corrosive gas environment of -10°C to 40°C and a relative humidity of no more than 80%.
- b) Storage requires anti-static measures, such as placing it in static foam or placing it in an anti-static box.

9.7 Module Protection

9.7.1 Optical interface protection requirements

- a) When the optical interface protection module is not in use or during installation, the optical interface is required to wear a dust cap/plug.
- b) Before testing the module, the optical interface is required to be wiped with a dust-free cotton swab dipped in alcohol. The wiping method is as follows:
Use a clean dust-free cotton swab dipped in an appropriate amount of alcohol and wipe it in one direction. When wiping, turn the cotton swab appropriately. Each cotton swab should be wiped no more than 3 times. Wait until the alcohol has completely evaporated before plugging or unplugging. Before plugging or unplugging, it is required to wipe the optical port connected to the jumper in the same way.
- c) If the optical module requires three-proof paint protection, it is recommended to use non-volatile three-proof paint and use a brushing process. And further processing of light port protection is required before brushing.

9.7.2 Electrical interface protection requirements

- a) After the module is unpacked, soldering must be completed within 24 hours.
- b) No hard scratches are allowed on the electrical interface soldering of the module.

9.7.3 Module electrostatic protection requirements

- a) The optical module is an ESD sensitive device, please pay attention to the electrostatic protection of the module.
- b) The turnover tool box is required to use a clean anti-static box turnover module, or directly use a module packaging box for turnover.
- c) When operating the module, the operator is required to wear an anti-static wrist strap and finger cots, and the wrist strap must be well grounded.
- d) It is forbidden to touch the module directly with bare hands.