

## RF photoelectric conversion module

### Table of Contents

Radio Frequency optical module	
10MHz ~ 2GHz non temperature-controlled RF optical transmission module	
2GHz ~ 4GHz non temperature-controlled RF optical transmission module	
10MHz ~ 2GHz direct-modulated temperature-controlled RF optical transmission module	
400MHz ~ 12GHz direct-modulated temperature-controlled wideband RF optical transmission module	
2GHz ~ 18GHz direct-modulated temperature-controlled wideband RF optical transmission module	
2 GHz ~ 18GHz external-modulated wideband RF optical transmission module	
Laser emission module	

### 10MHz ~ 2GHz non temperature-controlled RF optical transmission module

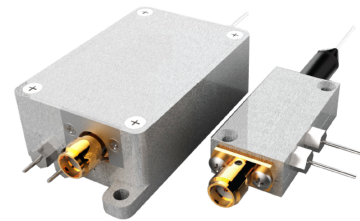

#### Functional overview

RF optical transmission module mainly achieve 10MHz ~ 500MHz, 500MHz ~ 1GHz, 1GHz ~ 2GHz RF signal transmission by fiber. The product consists of a RF optical emission module and a RF optical receiving module. Two modules are used in pairs. The radio-frequency signal enters the launch module and is tuned into the optical signal, which is transferred into the receiving module via fiber optic transmission, is eventually demodulated into the RF signal on the output port.

The product can realize the transmission of radio frequency signal without distortions and has the advantages of table performance and high reliability, which is widely used in electronic, ship, weapon and other fields

#### The main features

- ◆ Internal setting automatic light power control (APC) circuit to ensure the stable output of light power
- ◆ The product has extremely low phase noise, the transmission bandwidth is large whose index is superior
- ◆ small size, low power consumption, light weight, easy to use and install
- ◆ The product compatibility is strong, and interchangeability of the same type model product is good

#### Performance index

Power interface	
Parameter	Value
The power supply voltage	DC 5V±5%
workingcur	transmitter module ≤0.5A



rent	receiving module	≤0.2A
power interface		feedthrough capacitor
<b>Radio frequency signal interface</b>		
Test conditions:①Normal temperature ②RF optical transmission module is not added to any amplification.		
Parameter		Value
Frequency range	10MHz~500MHz	
	500MHz~1GHz	
	1GHz~2GHz	
Link gain	-24dB~-20dB	
Flatness In Band	±1dB	
P-1dB (Input)	10dBm	
Noise Figure	≤40dB	
Harmonic suppression	≤-30dBc (0dBm Input)	
Scattering	≤-60dBc (0dBm Input)	
The phase noise	≤-140dBc/Hz@1kHz	
Input and output impedance	50Ω	
Input and output VSWR	≤2: 1	
Radio frequency signal interface		SMA (socket)
<b>Optical interface</b>		
Working wavelength	1310nm、1550nm Optional	
Transmission mode	SM (single-mode)	
Fiber Interface	FC/APC	
<b>Environmental index</b>		
Service temperature	-40℃~70℃	
Storage Temperature	-40℃~85℃	
Relative humidity	10%~90% (25℃)	
<b>Brief of appearance</b>		
Outline dimension of transmitter module	56mm (length) ×30mm (width) ×15mm (height)	
Outline dimension of receiving module	33mm (length) ×17mm (width) ×11mm (height)	
Color of crate	Nickel white	
Material of crate	aluminium alloy 6061	



weight (not including packaging box)	≤0.15kg
--------------------------------------	---------

### DIMENSION FIGURE

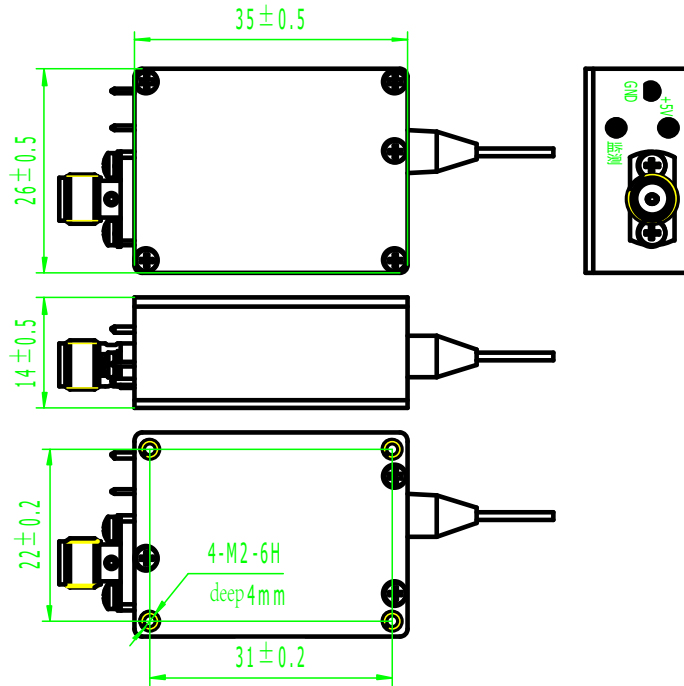

Figure1 Dimension figure of RF optical emission module

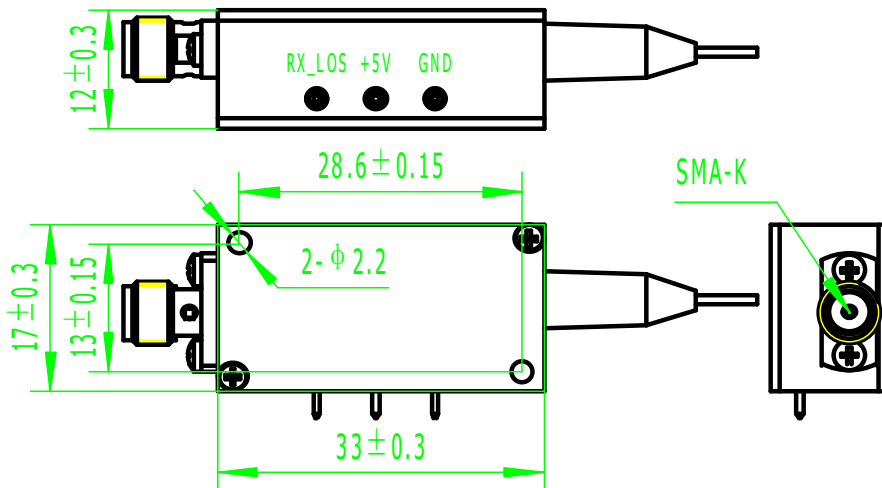

Figure2 Outline and installing dimension of RF optical receiving module

### Ordering Information

Working frequency	Workig wave length	RF optical emission module	RF optical receiving transmission module
-------------------	--------------------	----------------------------	--



10MHz ~ 500MHz	1310nm	TMG16-10M500M-314-301TS -L0.5	TMG16-10M500M-314-301RS -L0.5
	1550nm	TMG16-10M500M-314-501TS -L0.5	TMG16-10M500M-314-501RS -L0.5
500MHz ~ 1GHz	1310nm	TMG16-500M1G-314-301TS-L0.5	TMG16-500M1G-314-301RS-L0.5
	1550nm	TMG16-500M1G-314-501TS-L0.5	TMG16-500M1G-314-501RS-L0.5
1GHz~ 2GHz	1310nm	TMG16-1G2G-314-301TS-L0.5	TMG16-1G2G-314-301RS-L0.5
	1550nm	TMG16-1G2G-314-501TS-L0.5	TMG16-1G2G-314-501RS-L0.5

**Comment:** The "-L0.5" in the model indicates that the length of the module tail is 0.5 meters. Besides, the length of 0.2 meters, 0.8 meters and 1 meter is optional.

## 2GHz ~ 4GHz non temperature-controlled RF optical transmission module

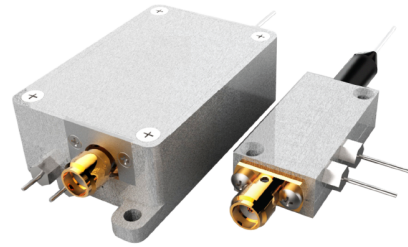

### Functional overview

RF optical transmission module mainly achieve 2GHz ~ 4GHz RF signal transmission by fiber. The product consists of a RF optical emission module and a RF optical receiving module. Two modules are used in pairs. The radio-frequency signal enters the launch module and is tuned into the optical signal, which is transferred into the receiving module via fiber optic transmission, is eventually demodulated into the RF signal on the output port.

The product can realize the transmission of radio frequency signal without distortions and has the advantages of table performance and high reliability, which is widely used in electronic, ship, weapon and other fields.

### The main features

- ◆ Internal setting automatic light power control (APC) circuit to ensure the stable output of light power
- ◆ The product has extremely low phase noise, the transmission bandwidth is large whose index is superior
- ◆ small size, low power consumption, light weight, easy to use and install
- ◆ The product compatibility is strong, and interchangeability of the same type model product is good

### Performance index

Power interface of optical transmission module	
Parameter	Value
The power supply voltage	DC 5V±5%
Working current	transmitter module ≤0.5A
	receiving module ≤0.2A
Power interface	Feed-through capacitor
Radio frequency signal interface	
Test conditions:①Normal temperature ②RF optical transmission module is not added to any amplification.	
Parameter	Value
Frequency range	2GHz~4GHz
Link gain	-24dB~-20dB
Flatness In Band	±1.5dB



<b>P-1dB (Input)</b>	<b>8dBm</b>
<b>Noise Figure</b>	<b>≤43dB</b>
<b>Harmonic suppression</b>	<b>≤-30dBc (0dBm Input)</b>
<b>Scattering</b>	<b>≤-60dBc (0dBm Input)</b>
<b>The phase noise</b>	<b>≤-120dBc/Hz@1kHz</b>
<b>Input and output impedance</b>	<b>50Ω</b>
<b>Input and output VSWR</b>	<b>≤2: 1</b>
<b>Optical interface</b>	
<b>Working wavelength</b>	<b>1310nm/1550nm</b>
<b>Transmission mode</b>	<b>SM (single-mode)</b>
<b>Fiber Interface</b>	<b>FC/APC</b>
<b>Environmental index</b>	
<b>Service temperature</b>	<b>-40℃~70℃</b>
<b>Storage Temperature</b>	<b>-40℃~85℃</b>
<b>Relative humidity</b>	<b>10%~90% (25℃)</b>
<b>Brief of appearance</b>	
<b>Outline dimension of emission module</b>	<b>56mm (length) ×30mm (width) ×15mm (height)</b>
<b>Outline dimension of receiving module</b>	<b>33mm (length) ×17mm (width) ×11mm (height)</b>
<b>Color of crate</b>	<b>Nickel white</b>
<b>Material of crate</b>	<b>aluminium alloy 6061</b>
<b>Weight (not including packaging box)</b>	<b>≤0.15kg</b>



**DIMENSION FIGURE**

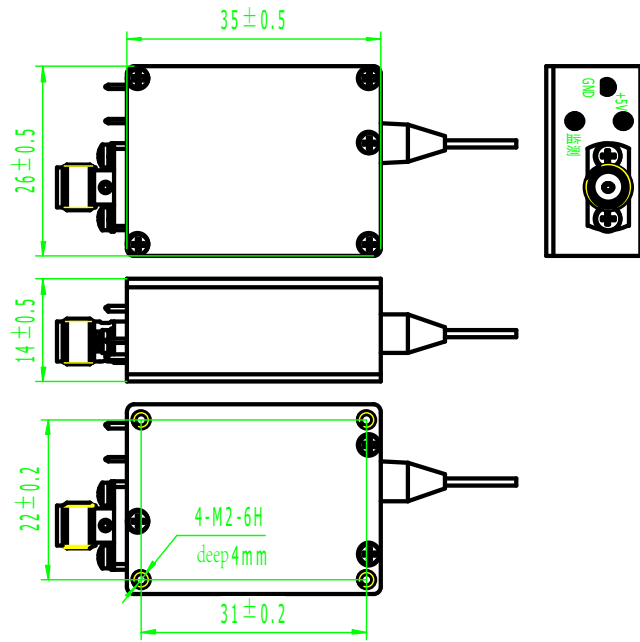

**Figure1 DIMENSION FIGURE of RF optical emission module**

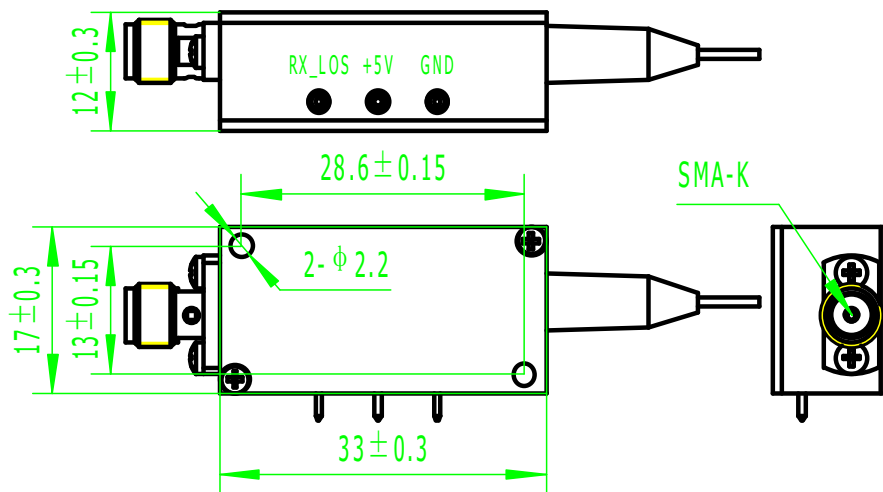

**Figure2 DIMENSION FIGURE of RF optical receiving module**

**Ordering Information**

Working wavelength	RF optical emission module	RF optical receiving module
1310nm	TMG16-2G4G-314-301TS-L0.5	TMG16-2G4G-314-301RS-L0.5
1550nm	TMG16-2G4G-314-501TS-L0.5	TMG16-2G4G-314-501RS -L0.5



**Comment:** The "-L0.5" in the model indicates that the length of the module tail is 0.5 meters. Besides, the length of 0.2 meters, 0.8 meters and 1 meter is optional.

## 10MHz ~ 2GHz temperature-controlled RF optical transmission module



### Functional overview

The series of RF optical transmission module mainly achieve 10MHz ~ 500MHz, 500MHz ~ 1GHz, 1GHz ~ 2GHz RF signal transmission by fiber. The product consists of a RF optical emission module and a RF optical receiving module. Two modules are used in pairs. The radio-frequency signal enters the launch module and is tuned into the optical signal, which is transferred into the receiving module via fiber optic transmission, is eventually demodulated into the RF signal on the output port.

The product can realize the transmission of radio frequency signal without distortions and has the advantages of table performance and high reliability, which is widely used in electronic, ship, weapon and other fields

### The main features

- ◆ Internal setting automatic temperature control (ATC) circuit, and Performance stability in the working temperature range is good.
- ◆ Internal setting automatic light power control (APC) circuit to ensure the stable output of light power
- ◆ Using high linearity DFB-LD and PD, and receiver sensitivity is high
- ◆ having the function of reporting the optical power status information and monitoring in real-time the entire optical transmission system.
- ◆ The product compatibility is strong, and the same type product can be interchanged.

### Performance index

Power interface		
Parameter		Value
The power supply voltage		DC 12V±5%
Working current	transmitter module	≤0.5A
	receiving module	≤0.2A
Power interface		F102Z10J053-139
<b>Radio frequency signal interface</b>		
Test conditions:①Normal temperature ②RF optical transmission module is not added to any amplification.		





Pparameter	Value
Frequency range	10MHz~500MHz
	500MHz~1GHz
	1GHz~2GHz
Link gain	-24dB~-20dB
Flatness In Band	±1dB
P-1dB (Input)	10dBm
Noise Figure	≤38dB
Harmonic suppression	≤-30dBc (0dBm Input)
Scattering	≤-60dBc (0dBm Input)
The phase noise	≤-140dBc/Hz@1kHz
Input and output impedance	50Ω
Input and output VSWR	≤2: 1
Radio frequency signal interface	SMA (socket)
<b>Optical interface</b>	
Working wavelength	1310nm/1550nm /DWDM(Optional)
Transmission mode	SM (single-mode)
Fiber Interface	FC/APC
<b>Environmental index</b>	
Service temperature	-40℃/-55℃~70℃
Storage Temperature	-40℃/-55℃~85℃
Relative humidity	10%~90% (25℃)
<b>Brief of appearance</b>	
Outline dimension of module	113mm (length) ×57.5mm (width) ×35mm (height)
Color of crate	Silver gray
Material of crate	aluminium alloy 6061
Weight (not including packaging box)	≤0.5kg



DIMENSION FIGURE

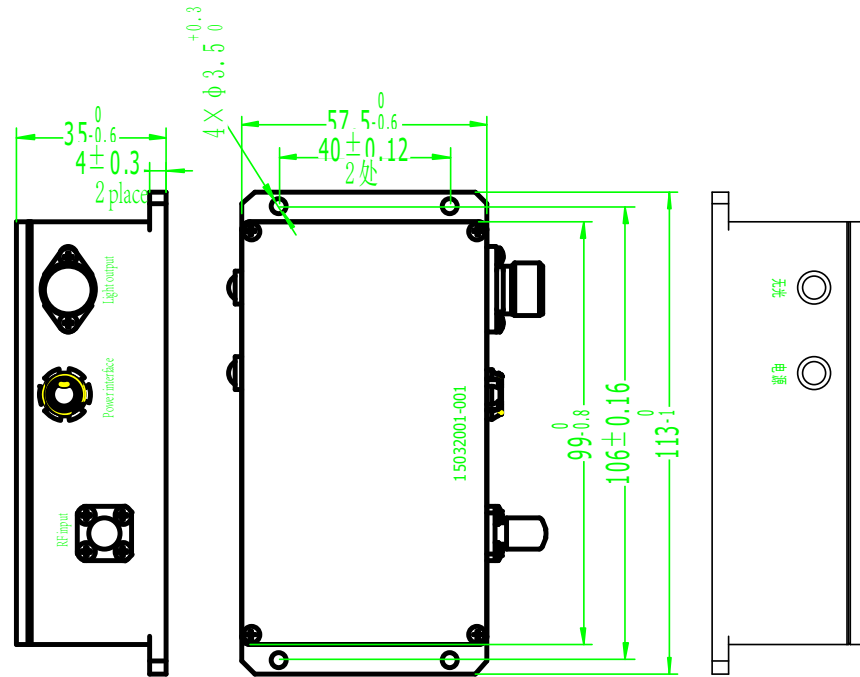
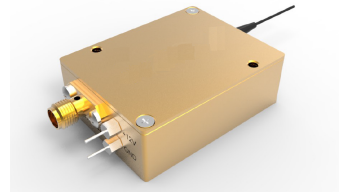

Figure1 DIMENSION FIGURE of RF optical transmission module

Ordering Information

Working frequency	Working wavelength	RF optical emission module	RF optical receiving module
10MHz~500MHz	1310nm	TMG16-10M500M-114-301TS	TMG16-10M500M-114-301RS
	1550nm	TMG16-10M500M-114-501 TS	TMG16-10M500M-114-501RS
500MHz~1GHz	1310nm	TMG16-500M1G-114-301TS	TMG16-500M1G-114-301RS
	1550nm	TMG16-500M1G-114-501TS	TMG16-500M1G-114-501RS
1GHz~2GHz	1310nm	TMG16-1G2G-114-301TS	TMG16-1G2G-114-301RS
	1550nm	TMG16-1G2G-114-501TS	TMG16-1G2G-114-501RS

## 400MHz ~ 12GHz direct-modulated temperature-controlled wideband RF optical transmission module



### Functional overview

The RF optical transmission module mainly achieve 400MHz ~ 12GHz RF signal transmission by fiber. The product consists of a RF optical emission module and a RF optical receiving module. Two modules are used in pairs. The radio-frequency signal enters the launch module and is tuned into the optical signal, which is transferred into the receiving module via fiber optic transmission, is eventually demodulated into the RF signal on the output port.

The product can realize the transmission of radar signal, the delay of phased array radar signal and the RF communication of various electronic countermeasures.

### The main features

- ◆ 400MHz ~ 12GHz ultra-wideband range
- ◆ Internal setting automatic temperature control (ATC) circuit, and performance stability in the working temperature range is good.
- ◆ Internal setting automatic light power control (APC) circuit to ensure the stable output of light power
- ◆ small size, light weight, easy to install

### Performance index

Power interface of optical emission module	
Parameter	Value
The power supply voltage	
DC 5V±5%、DC -5V±5%	
Working current	transmitter module
	receiving module
≤0.8 A	
≤0.05 A	
Power interface	
Feed-through capacitor	
Power interface of optical receiving module	
Parameter	Value
The power supply voltage	
DC 12V±5%	
Working current	
≤0.01 A	
Power interface	
Feed-through capacitor	
Radio frequency signal interface	
Test conditions:①Normal temperature ②RF optical transmission module is not added to any amplification.	



Parameter	Value
Frequency range	0.4GHz~12GHz
Link gain	-27dB~-21dB
Flatness In Band	±2dB
P-1dB (Input)	12dBm
Noise Figure	≤43dB
Input and output impedance	50Ω
Input and output VSWR	≤2: 1
Radio frequency signal interface	SMA (socket)
<b>Optical interface</b>	
Working wavelength	1310nm/1550nm /DWDM(Optional)
Transmission mode	SM (single-mode)
Fiber Interface	FC/APC
<b>Environmental index</b>	
Service temperature	-40℃/-55℃~70℃
Storage Temperature	-40℃/-55℃~85℃
Relative humidity	10%~90% (25℃)
<b>Brief of appearance</b>	
Outline dimension of module	62mm (length) ×40mm (width) ×27mm (height)
Color of crate	Nickel white
Material of crate	aluminium alloy 6061
Weight (not including packaging box)	≤0.15kg



DIMENSION FIGURE

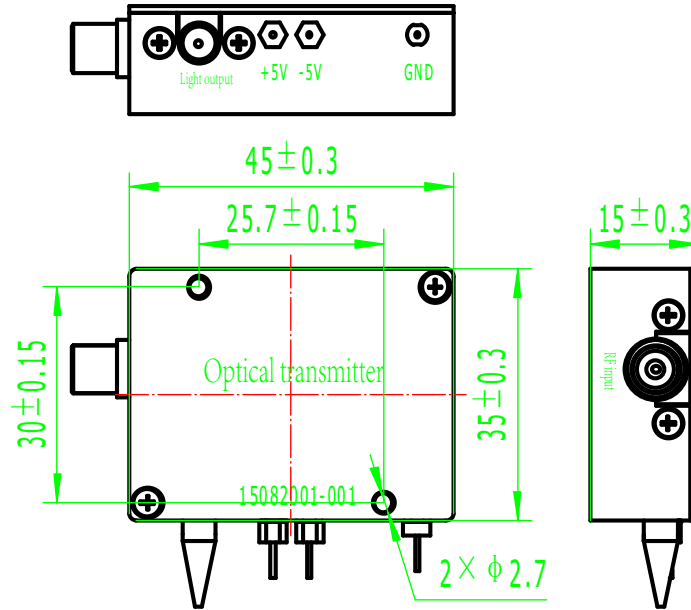

Figure1 DIMENSION FIGURE of RF optical emission module

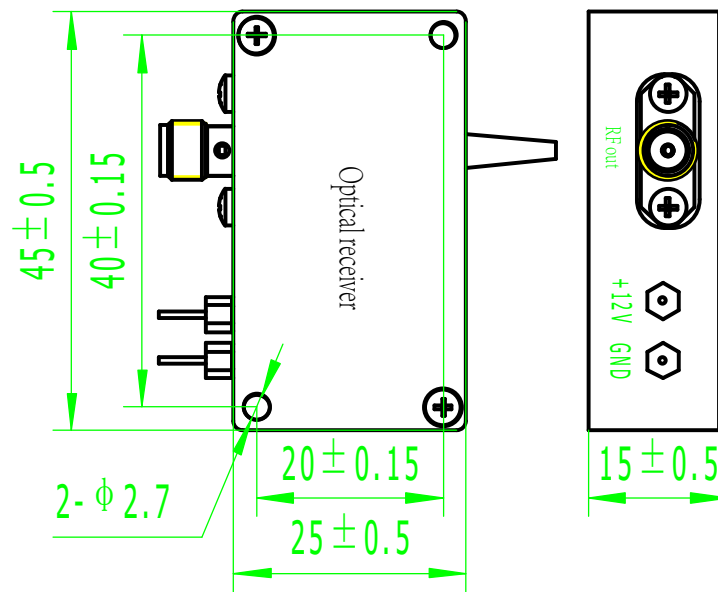

Figure2 DIMENSION FIGURE of RF optical receiving module

Ordering Information

Working wavelength	RF optical emission module	RF optical receiving module
1310nm	TMG16-400M12G-314-301TS-L0.5	TMG16-400M12G -314-301RS-L0.5
1550nm	TMG16-400M12G-314-501TS-L0.5	TMG16-400M12G-314-501RS-L0.5

Comment: The "-L0.5" in the model indicates that the length of the module tail is 0.5 meters. Besides, the length of 0.2 meters, 0.8 meters and 1 meter is optional.

## 2GHz ~ 18GHz direct-modulated temperature-controlled wideband RF optical transmission module

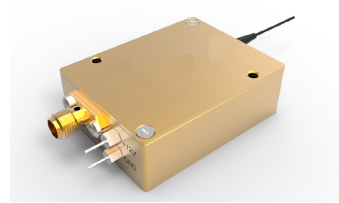

### Functional overview

The RF optical transmission module mainly achieve 2GHz ~ 18GHz RF signal transmission by fiber. The product consists of a RF optical emission module and a RF optical receiving module. Two modules are used in pairs. The radio frequency light transmitting module modulates the radio frequency signal into an optical signal and sends it to the radio frequency light receiving module, and the receiving module demodulates the received optical signal into a radio frequency signal.

The product can realize the transmission of radar signal, the delay of phased array radar signal and the RF communication of various electronic countermeasures.

### The main features

- ◆ 2GHz ~ 18GHz ultra-wideband range
- ◆ Internal setting automatic temperature control (ATC) circuit, and performance stability in the working temperature range is good.
- ◆ Internal setting automatic light power control (APC) circuit to ensure the stable output of light power.
- ◆ Small size, light weight, easy to install.

### Performance index

Power interface of optical emission module	
Parameter	Value
The power supply voltage	DC 5V±5%、DC -5V±5%
Working current (DC 5V)	≤0.6 A
Working current(DC -5V)	≤0.07A
Power interface	Feed-through capacitor
Power interface of optical receiving module	
Parameter	Value
The power supply voltage	DC 12V±5%
Working current	≤0.01 A
Power interface	Feed-through capacitor
Radio frequency signal interface	
Test conditions:①Normal temperature ②RF optical transmission module is not added to any amplification.	
Parameter	Value



Frequency range	2GHz~18GHz
Link gain	-29dB~-20dB
Flatness In Band	±2dB
P-1dB (Input)	12dBm
Noise Figure	≤45dB
Input and output impedance	50Ω
Input and output VSWR	≤3: 1
Radio frequency signal interface	SMA (socket)
<b>Optical interface</b>	
Working wavelength	1310nm/1550nm /DWDM(Optional)
Transmission mode	SM (single-mode)
Fiber Interface	FC/APC
<b>Environmental index</b>	
Service temperature	-40℃/-55℃~70℃
Storage Temperature	-40℃/-55℃~85℃
Relative humidity	10%~90% (25℃)

### Brief of appearance

Outline dimension of module	62mm (length) ×40mm (width) ×27mm (height)
Color of crate	Nickel white
Material of crate	aluminium alloy 6061
Weight (not including packaging box)	≤0.15kg



DIMENSION FIGURE

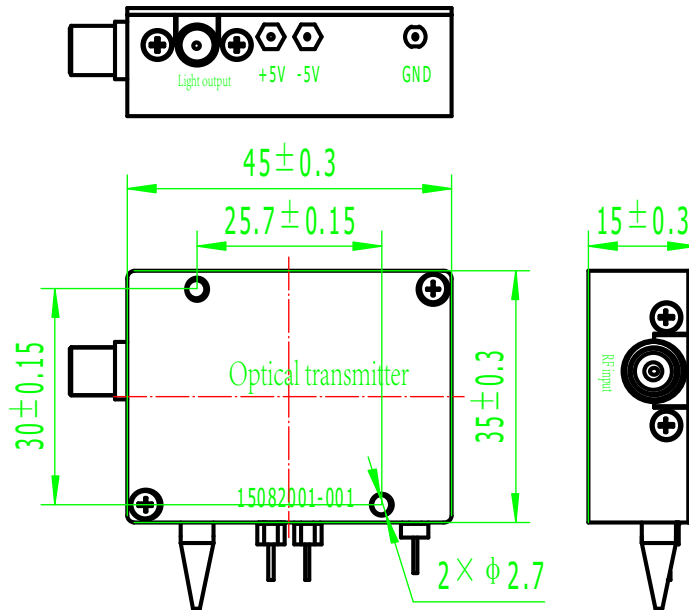

Figure1 DIMENSION FIGURE of RF optical emission module

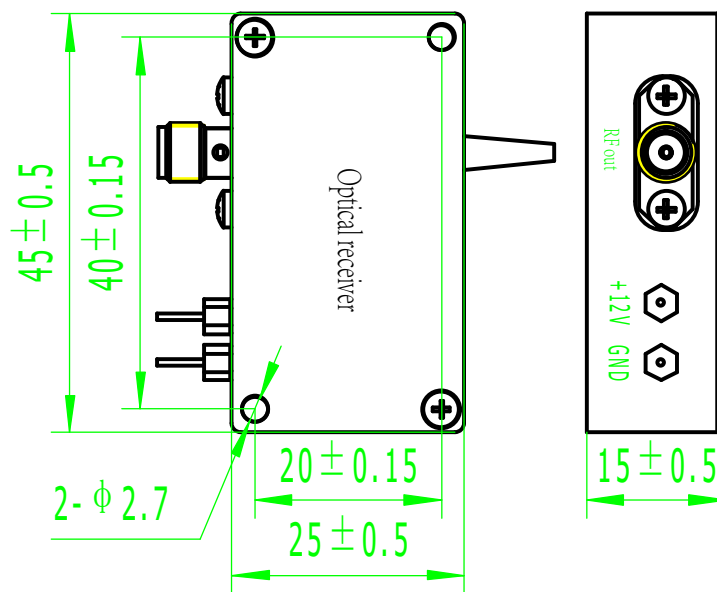

Figure2 DIMENSION FIGURE of RF optical receiving module

Ordering Information

Working wavelength	RF optical emission module	RF optical receiving module
1310nm	TMG16-2G18G-314-301TS-L0.5	TMG16-2G18G-314-301RS-L0.5
1550nm	TMG16-2G18G-314-501TS-L0.5	TMG16-2G18G-314-501RS-L0.5

Comment: The "-L0.5" in the model indicates that the length of the module tail is 0.5 meters. Besides, the length of 0.2 meters, 0.8 meters and 1 meter is optional.





## 2GHz ~ 18GHz external-modulated temperature-controlled wideband RF optical transmission module

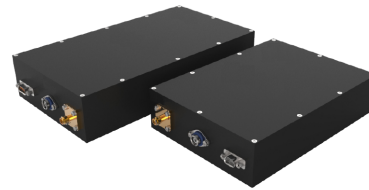

### Functional overview

The RF optical transmission module mainly achieve 2GHz ~ 18GHz RF signal transmission by fiber. The product consists of a RF optical emission module and a RF optical receiving module. Two modules are used in pairs. The radio frequency light transmitting module realizes the optical modulation function of the radio frequency signal, and the radio frequency receiving module realizes the optical demodulation function of the radio frequency signal.

### The main features

- ◆ Built-in software program to automatically detect the best modulation point of the modulator
- ◆ Internal setting automatic temperature control (ATC) circuit, and performance stability in the working temperature range is good.
- ◆ Internal setting automatic light power control (APC) circuit to ensure the stable output of light power.
- ◆ Using high linearity DFB-LD and PD, and receiver sensitivity is high
- ◆ High frequency, wide working bandwidth, distant transmission distance.

### Performance index

Power interface of optical emission module	
Parameter	Value
The power supply voltage	DC 5V±5%、DC -5V±5%
	DC 12V±5%、DC -12V±5%
Working current	DC 5V ≤0.5 A
	DC -5V ≤0.3 A
	DC 12V ≤0.1 A
	DC -12V ≤0.1 A
Power interface	J30J-15ZKP
Power interface of optical receiving module	
Parameter	Value
The power supply voltage	DC 12V±5%
Working current	≤0.3 A
Power interface	J30J-15ZKP
Radio frequency signal interface	
Test conditions:①Normal temperature ②RF optical transmission module is not	



added to any amplification.	
<b>Parameter</b>	<b>Value</b>
Frequency range	2GHz~18GHz
Link gain	-26dB~-34dB
Flatness In Band	±2dB
P-1dB (Input)	20dBm
Harmonic suppression	≤-35dBc (0dBm Input)
Scattering	≤-60dBc (0dBm Input)
Noise Figure	≤43dB
Input and output impedance	50Ω
Input and output VSWR	≤2: 1
Radio frequency signal interface	SMA (socket)
<b>Optical interface</b>	
Working wavelength	1550nm
Transmission mode	SM (single-mode)
Fiber Interface	FC/APC
<b>Environmental index</b>	
Service temperature	-40℃~70℃
Storage Temperature	-40℃~85℃
Relative humidity	10%~90% (25℃)

### Brief of appearance

Outline dimension of emission module	195mm (length) ×108mm (width) ×40mm (height)
Outline dimension of receiving module	150mm (length) ×108mm (width) ×36mm (height)
Color of crate	Matt black
Material of crate	aluminium alloy 6061
Weight (not including packaging box)	≤2kg



DIMENSION FIGURE

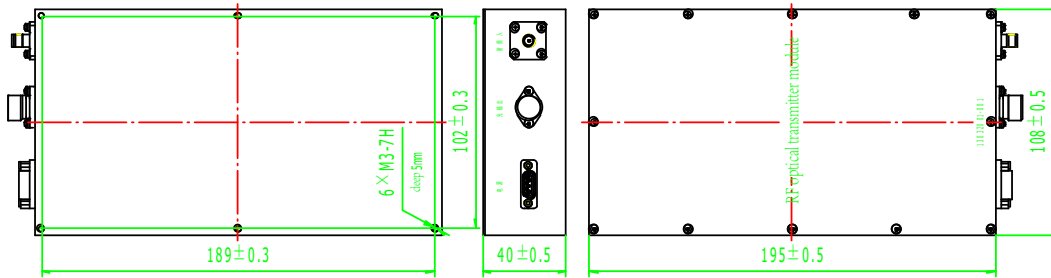

Figure1 DIMENSION FIGURE of RF optical emission module

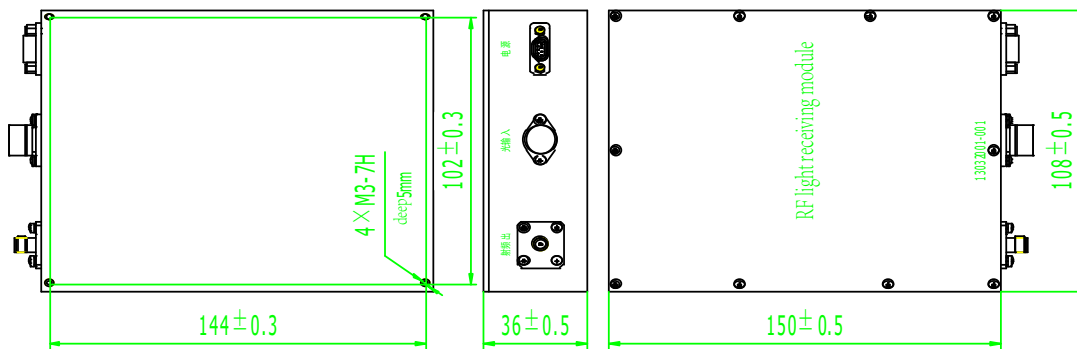

Figure2 DIMENSION FIGURE of RF optical receiving module

Ordering Information

working wavelength	RF optical emission module	RF optical receiving module
1550nm	TMG16-8G18G-114-501TS	TMG16-8G18G-114-501RS



## Laser emission module

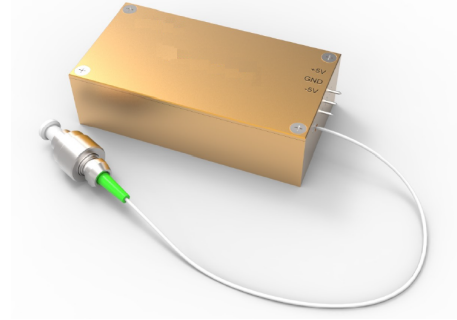

### Functional overview

Laser emission module achieves the output of high power laser, which is mainly used in conjunction with external modulator to realize Transmission of RF signal through external modulation technology.

### The main features

- ◆ Internal setting automatic temperature control (ATC) circuit, and performance stability in the working temperature range is good.
- ◆ Internal setting automatic light power control (APC) circuit to ensure the stable output of light power.

### Performance index

Power interface of laser emission module		Value
Parameter		Value
The power supply voltage		DC 5V±5%、DC -5V±5%
Working current	DC 5V	≤0.5 A
	DC -5V	≤0.3 A
Power interface		Insulation terminal
Optical interface		
Optical power		30W, 40W, etc. (optional)
Working wavelength		1550nm/DWDM (optional)
Transmission mode		SM (single-mode)
Fiber Interface		FC/APC
Environmental index		
Service temperature		-40℃/-55℃~70℃
Storage Temperature		-40℃/-55℃~85℃
Relative humidity		10%~90% (25℃)

### Brief of appearance

Outline dimension of emission module	60mm (length) ×26mm (width) ×17mm (height)
Color of crate	Golden
Material of crate	aluminium alloy 6061



Weight (not including packaging box)	≤0.25kg
--------------------------------------	---------

DIMENSION FIGURE

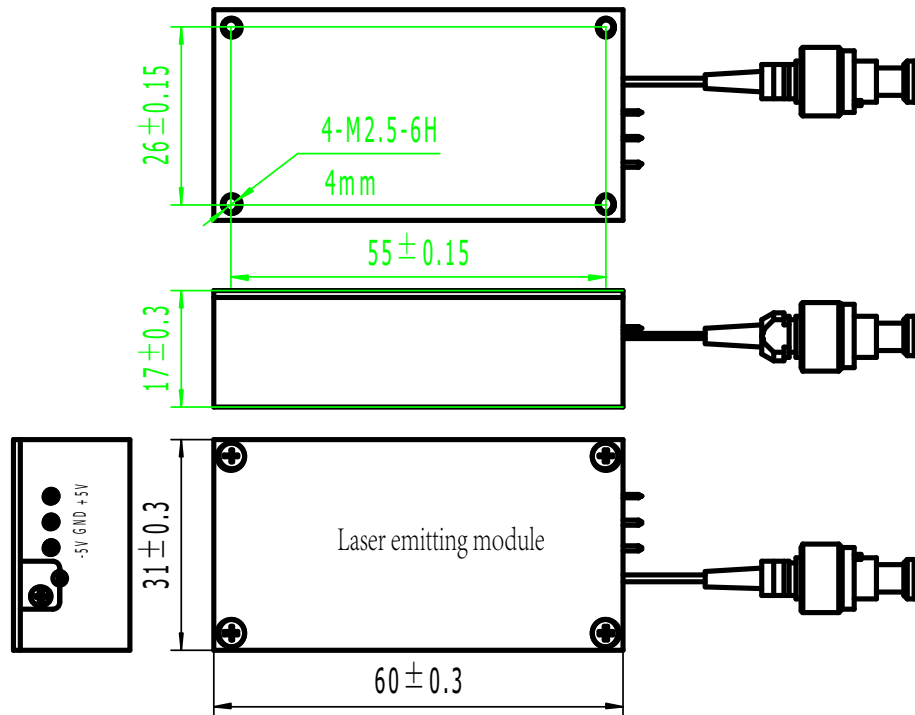

Figure1 Dimensions figure of laser emission module

Ordering Information

Working wavelength	Laser emission module
1550nm	TMZ-692